

## BASIC ASSEMBLY INSTRUCTIONS

# MIRAGE

## TABLE OF CONTENTS

Mirage® is available in many sizes – from 32” tall tabletops to 92” tall backwalls. The following set-up and repacking instructions depict our 10’ 92” Mirage, the most popular display in the world. All Mirage displays set up using the same sequence, although the size and number of components vary between models.

**Please read the entire section before attempting set-up.**

Although Skyline products are designed to withstand the rigors of a heavy trade show schedule, with many set-ups and take-downs, care should be taken when handling your display. Valuable graphic panels can be damaged if not properly handled. Place graphic panels in protective plastic bags provided before repacking. Be careful not to drop panels into the case as this could damage their edges.

If you have any questions about setting up your display or have lost components, call your local Skyline distributor.

For the number of your distributor, or the distributor in a city in which you are exhibiting, call Skyline at **+61 7 3268 7744**. Thank you for choosing Skyline – have a great show!

<b>Case Identification</b>		3
<b>Set-Up</b>		
	Component Identification	4
	Frame	5
	Channels	6
	End Panels	8
	Panels	9
<b>Repacking</b>		
	Oval Cases	10

## CASE IDENTIFICATION

**Oval Case** (*Tabletop displays have only 1 case.*)

Cases connect for easy transporting

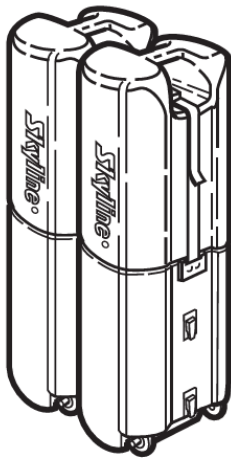

To disconnect, unbuckle straps.

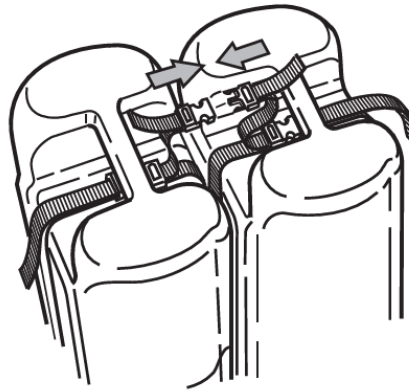

Tip Cases forward to separate cases at base

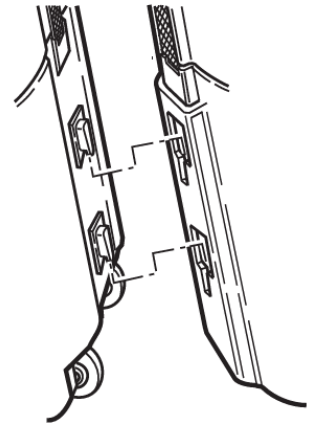

## COMPONENT IDENTIFICATION

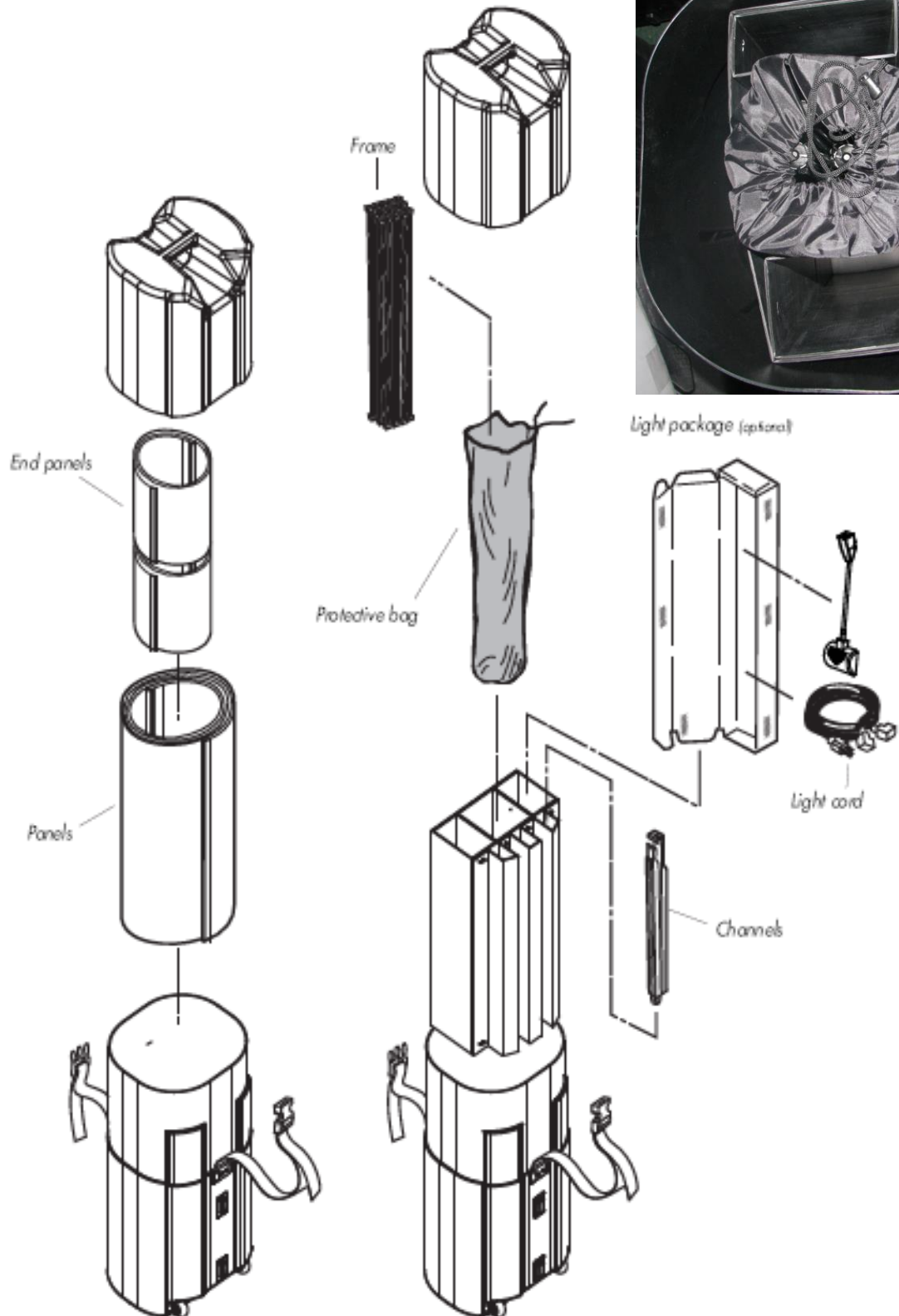

## FRAME

*Mirage® Advantage* Remove frame from protective bag in centre core of case.  
(Keep protective bag for repacking your frame.)

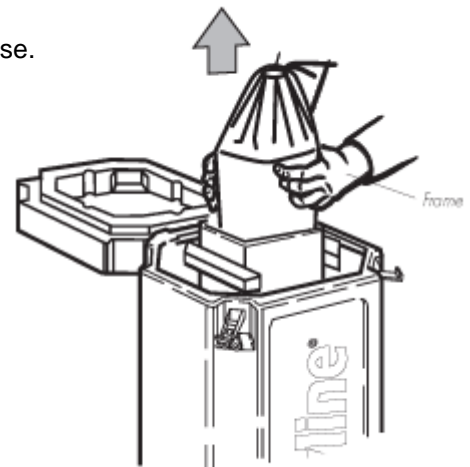

Place frame in standing position with row of yellow hubs up and facing you. Spread frame apart enough to grasp the rod in the centre of the frame.



Grasp frame rod with label attached in the centre of the frame and lift to expand frame.

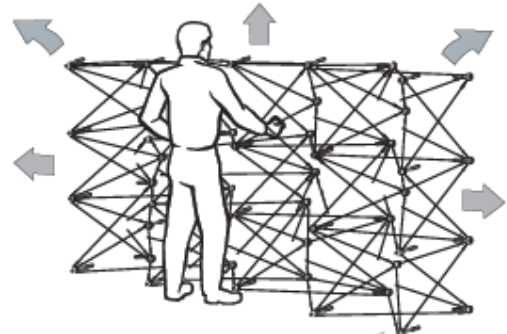

Frame connectors will magnetically snap together when the frame is fully expanded. Check to make sure all connectors do join and attach any that have not.

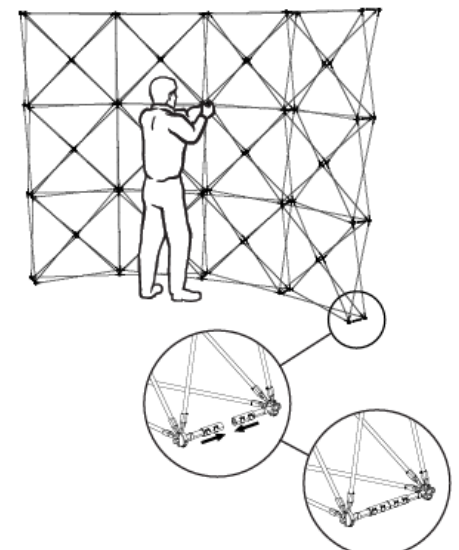

## CHANNELS

Remove channel from case core. Identify what lights you have, if any, before you install the channels (see below).

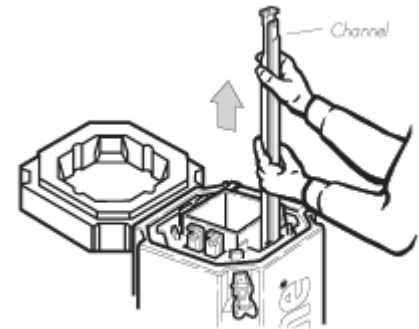

Your channels are hinged for easy set up. The light clip is on the top channel.

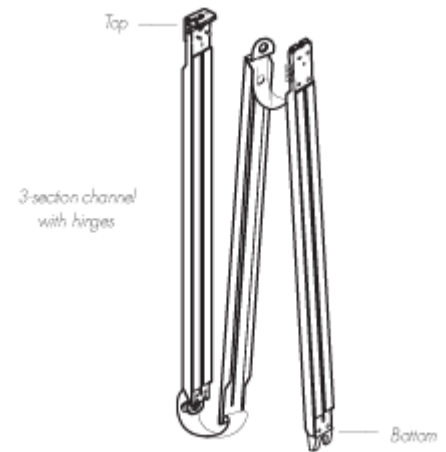

### **NOTE:**

If you have **no lights** or a backlit Marquee header proceed to **Step 5**.

If you have **Halogen lights** go directly to **Step 8-H** on page 10.

If you have **SkyTrak lights** go directly to **Step 8-S** on page 12.

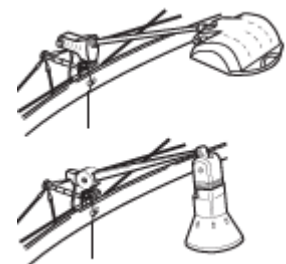

Channels are applied to all quadrants on front side of frame.  
Extra channels are applied to each end on back side of frame.

### Top Connection

Connect top channel section to top hub of display frame as shown.

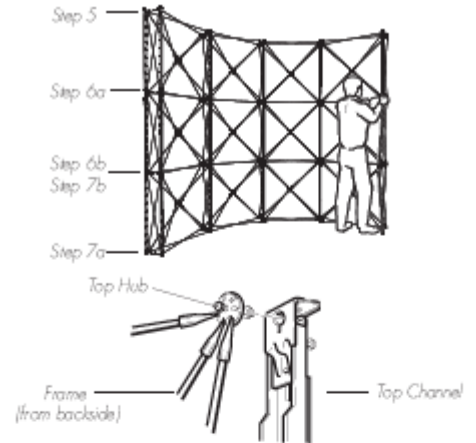

### Upper Centre Connection

Connect bottom of top channel to upper centre hub of display frame. Slide top of centre channel up onto same hub.

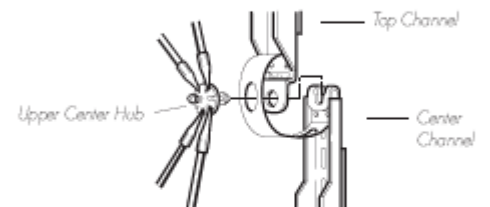

### Lower Centre Connection

Connect bottom of centre channel to lower centre hub of display frame. Go to Step 7 to connect bottom channel.

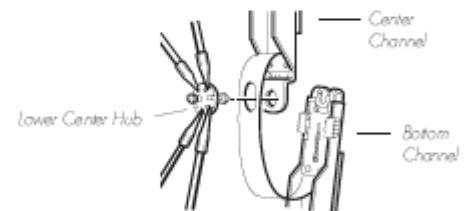

### Bottom Connection

Slide bottom of channel over bottom hub of display frame.

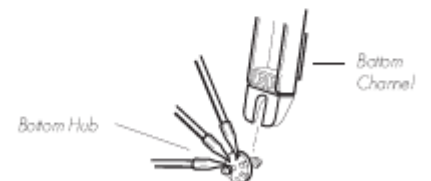

### Lower Centre Connection

Push down on the yellow tabs to depress spring-loaded locking mechanism. Push top of channel onto hub and release tabs.

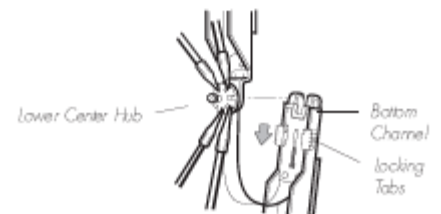

## END PANEL INSTALLATION

Form end panel into correct shape by hand.



Hook panel notches over v-shaped index pins at top of front and back channels.

**Note:**

*Allow panel to hang loosely from pins with panel completely outside channels.*

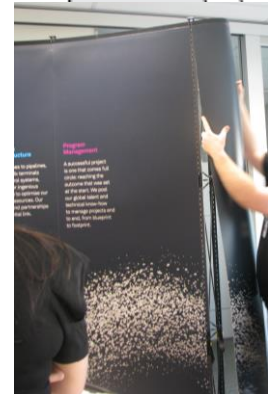

Begin matching outside edge of panel magnet with inside edge of inner channel magnet. Continue down panel matching edges of magnets until panel is smooth.



**Note:**

Do not kink panel. If a kink does occur, detach panel from channels and repeat forming procedure. The panels will always come off if it has a kink at the bottom during installation.

**Trick of the Trade:**

Cup hands around panel to assist the panel to attach to both the front and back channel at same time.

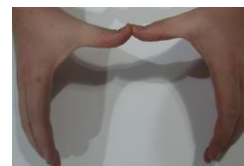



## PANEL INSTALLATION

Carefully remove panels 1 at a time from case and unroll on flat, clean surface.

**Hint:** Roll panels slightly tighter to remove from case.

Grasp panels on their edges making sure panel notches are on top. Hold the panel slightly concave to give it the rigidity needed to reach the top of the channel.

Hook the panel notch over the pin at the top of the channel.

Repeat for other side of panel.

Let panels attach to magnetic channels.

**Important:** Align graphic panels to match up.  
Realign if necessary.

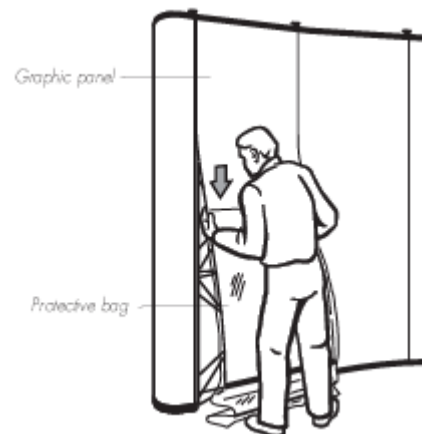
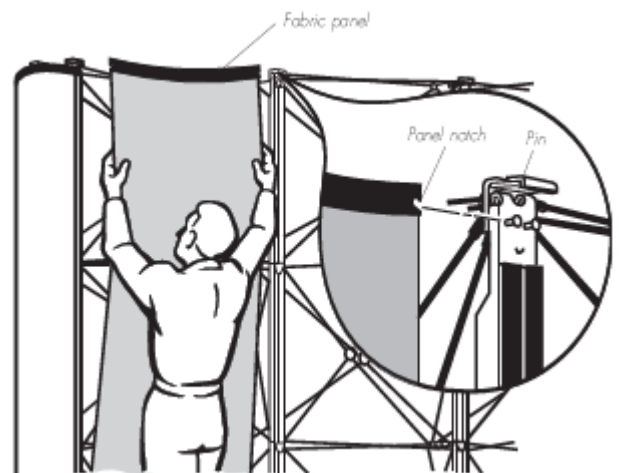
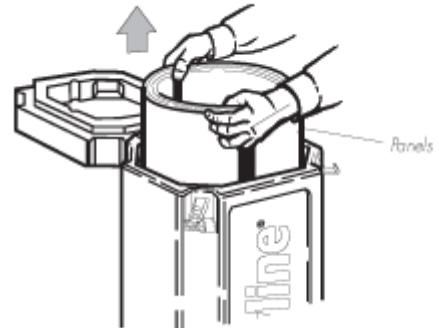

## REPACKING

Remove any accessories or lighting and replace in original packing.

Remove front panels and then the end panels. Being careful not to kink the panel.

Place the protective sheeting on the floor. Lay graphic panel with magnet facing upward and roll panel with magnet facing inwards.

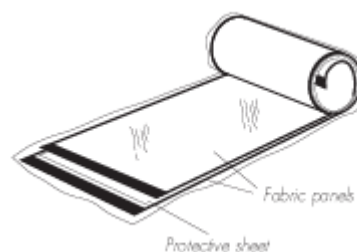

Do not force panels into cases. To avoid damaging magnets & panels in transit, allow panel to expand inside the case.

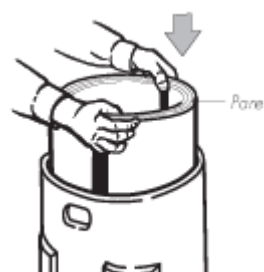

### **HINT:**

If storing graphics for a long period of time it is recommended that graphics are stored on a flat surface away from extreme hot or cold conditions.

To remove channels, go to the top of the bottom channel and depress the yellow tabs to unlock the connection.

Pull the bottom channel off of its hub.

Remove remaining channels by pulling the bottom of the channel off of its hub, then the top of the channel off of its hub.

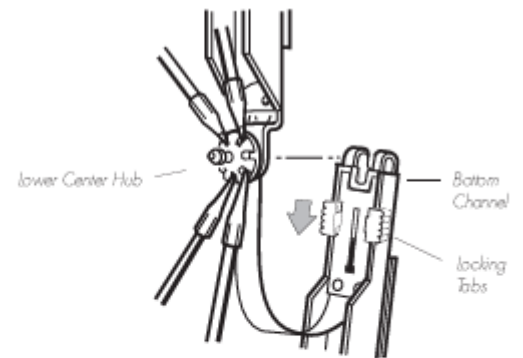

Fold channels and nest sections together as shown.

**Note:** Make sure that centre channel nests below pins on top channel (see side view)!

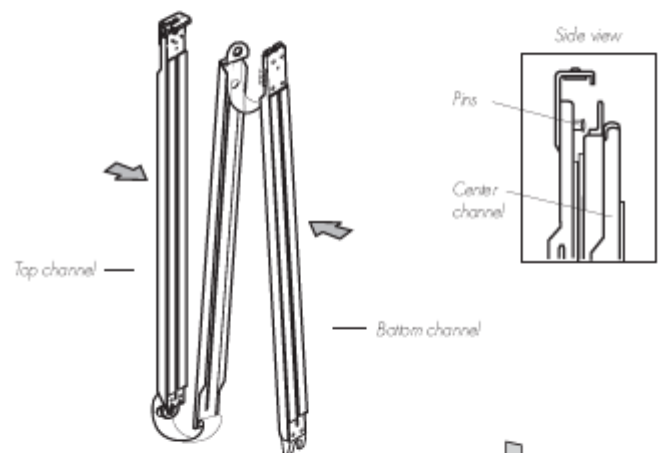

Place channels in core.

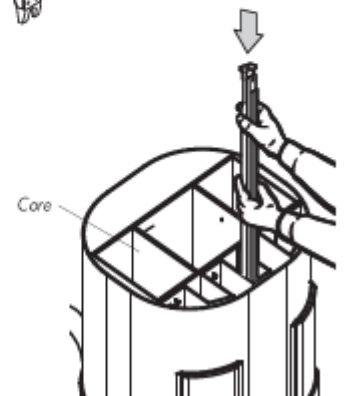

To collapse frame, tip the frame back slightly (to reduce floor friction) and pull the two halves of a connector apart in the centre of the frame. All remaining connectors should separate.

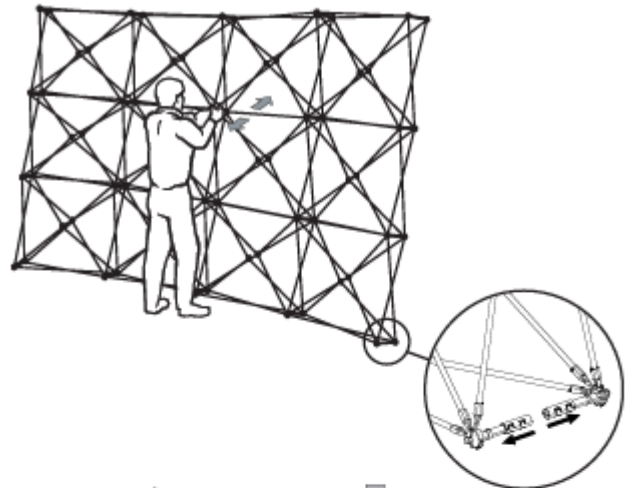

Support frame and slowly allow frame to collapse.

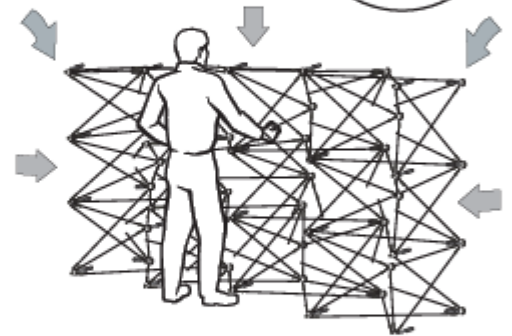

Place frame in protective bag.

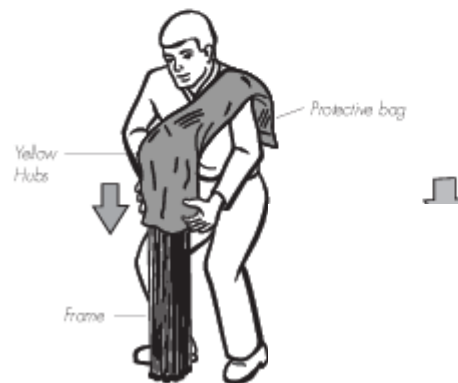

Place frame into case core

