

ARRIVE®

Portable Display & Workstation

Skyline®



Arrive® Display System –
Display & Workstation In One Case!



Arrive In Style With Ease

Arrive® gives you an entire banner stand display and highly-functional workstation in one easy-to-manage shippable case. Arrive easily converts from protective case to workstation so you can be ready to exhibit in less than 30 minutes with no case to hide or store. That means no waiting for your case after the show.

Single-Case Portability!

Arrive holds an entire 10' (3 m) banner stand display along with accessories and graphic wrap that transform your case into a branded workstation. Arrive case features a table top, graphic wrap, integral shelf, wire management and optional accessories to fit your needs.

Which banner stand display is right for you? Arrive works with Skyline Exalt® and Myriad® banner stand systems.



Exalt® Curved Banner Stand

The classic curved look and the ease of a banner stand! Exalt can be used in a linear format or, with the simple flick of levers, Exalt converts from linear to curved.



Myriad® Banner Stand

Myriad gives you a full inline display with just two lightweight banner stand units and a center fabric graphic panel. Myriad's built-in merchandising system combines the ability to display product or literature with the ease and convenience of a banner stand.



- 1 Accessory Pole**
Supports a digital picture player, shelf or literature holder, which are easy to attach and add functionality.
- 2 Counter Top**
Graphic or laminate surface is perfect for taking leads or displaying product.
- 3 Wire Management**
Built-in wire management conceals cords for a clean look.

- 4 Brilliant Graphics**
Printed in-house by experts using the latest technology.

- 5 Accessory Tray**
Accessory storage tray converts to a shelf to support a laptop or other useful exhibiting items. The tray stores and protects three exhibit lights and multiple accessories.

- 6 Graphic Table Wrap**
Match your display graphics for a cohesive brand presentation. Graphic wrap is easy to install and change out when your message changes.

The Magic of Arrive® – Everything In One Case!

Arrive with everything you need. Arrive® quickly transforms from a single banner stand case into a complete 10' (3 m) display and functional workstation tailored to fit your brand and show objectives.



Quick, Easy Installation

In just a few steps, Arrive goes from case to stylish workstation.



See the Magic of Arrive!

See the all features of the smartly-designed Arrive system.

skyline.com/product-videos/arrive



See How Easy Exhibiting Can Be

Arrive gives you so much in so little time. You'll be ready to exhibit in minutes.

skyline.com/product-videos/arrive

Exalt® Inline Display Weight: 30.8 lbs. (14 kg)

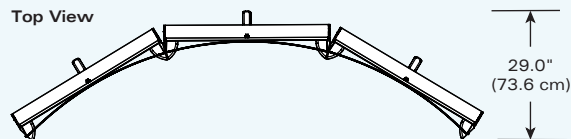

Front View

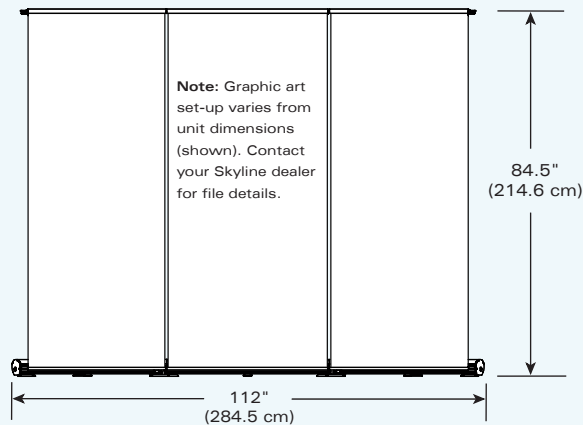

Arrive® Workstation

Weight: 37 lbs. (16.8 kg)

(Case closed)

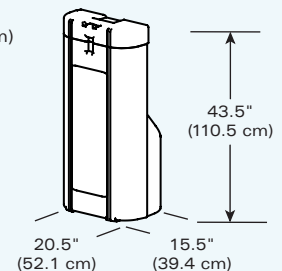

Myriad® Inline Display Weight: 26 lbs. (11.8 kg)

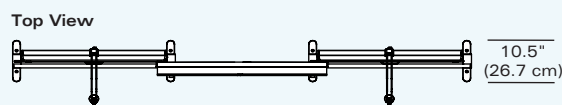

Front View

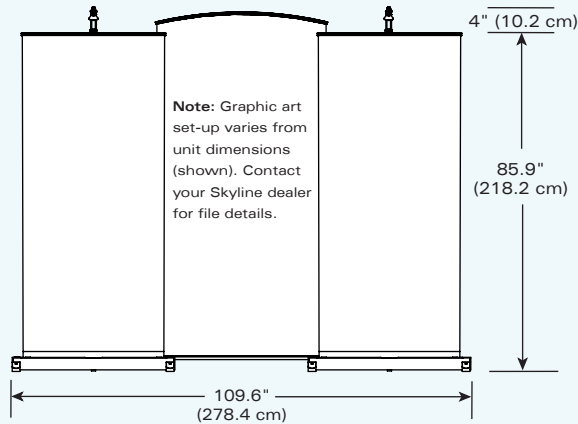

(Case converted)

